

PREFACE

Your choice of the products made by Jinan Langrui Detection Technology Co., Ltd. (Langry) is greatly appreciated. We are committed to deliver you excellent products and satisfied sales services. Please carefully read the instructions prior to use.

1. The instructions are prepared to provide the correct and complete descriptions of related products and data. However, we do not guarantee that there are no errors or omissions. Therefore, we will not bear responsibilities for any resulting consequences.

2. Langry keeps the right of updating the instructions without prior notice.

3. Langry bears no responsibilities for possible losses from data deviation or incorrect testing conclusion arising from instrument failure and other errors.

4. When the instrument is put into operation, it means that you have carefully read and had full picture of all terms in the instructions, and you have fully agreed to all the terms in the instructions.

5. Langry will not bear responsibilities for all the signed agreements violating the statement during the sales and services process not involving Langry.

1. Introduction of instrument



The penetration detection method is a new field detection method, which is based on the correlation between the depth of the test nail penetration into concrete and the concrete compressive strength. The compression working spring is used to add the load to the test nail penetration into concrete, and the concrete compressive strength is converted by the penetration depth of the test nail through the strength measurement curve.

Penetration method is widely used in concrete strength testing because of its advantages: 1. Simple operation; 2. Accurate test results; 3. Low cost of testing, etc.

1.1 Standard

ASTM C803

1.2 Components

SJY-1000B Penetration concrete strength detector Components

- 1.The host of penetrometer
- 2.Penetration depth measuring stick
- 3.Measuring nail(20 nails)

- 4.Measuring nail Gauge
- 5.Tightening wrench
- 6.Lever
- 7.Blowing dust ball
- 8.Grinding wheel
- 9.Instrument box

1.2 The host of penetrometer

(see the figure below)

It adopts mechanical penetration method, relying on the spring of special device to provide the energy needed for detection, because the the compression amount of the spring is the same each time, so that the energy released each time is the same, so as to ensure the accuracy and reliability of detection.

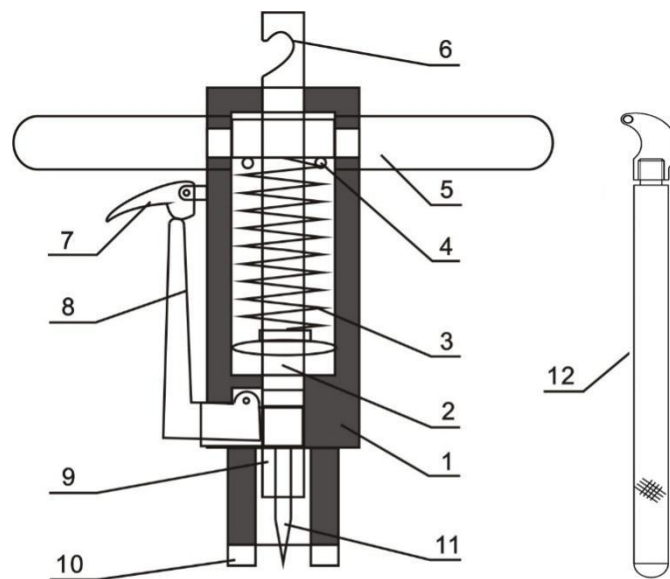

Figure 1 Structure Chart

- | | | | |
|-----------------------|--------------------|-------------------|----------------|
| 1.subject | 2.Penetration rod | 3.Working spring | 4.ADJUSTINGNUT |
| 5.handle | 6.stressing groove | 7.trigger | 8.pothook |
| 9.Measuring nail seat | 10.Flat head | 11.Measuring nail | 12.lever |

Penetration depth measuring stick (see below) :

It is used to measure the depth of the test hole produced by the host machine of the penetration instrument. The measured data is the actual depth without calculation, and zero is set at any point.

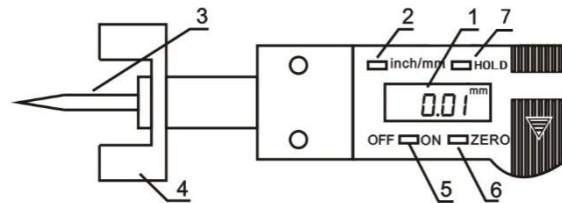

Figure 2 Penetration depth measuring stick

- | | | | |
|----------------|----------------------|------------|-------------|
| 1.LCD screen | 2.change-over switch | 3.Probe | 4.Flat head |
| 5.power switch | 6.Zero button | 7.hold key | |

1.3 Special measuring nail:

It is made of special steel after grinding, and it is a necessary special tool for the detection of the host machine of the penetration instrument.

After the measuring nail is inserted into the measuring nail seat of the penetration instrument host, the momentum is acquired from the energy released by the compression spring in the penetration instrument host, and it is penetrated into the concrete.

The special measuring nail has very strong hardness, which can ensure repeated use for several times without affecting the detection accuracy.

1.4 Nail gauge:

It is a tool to measure whether a nail can be used after being used for many times. When measuring the life of a nail, place the nail gauge on a horizontal plane, then put the root of the nail to be measured against one end of the gauge groove, and put the nail down along the direction of the gauge groove to see whether the nail can pass through the gauge

groove. If it passes, the nail cannot be used.

1.5 Tightening wrench:

It is used to tighten the nut of the measuring nail seat to fix the measuring nail.

1.6 Lever:

It is an auxiliary tool when the the host is working. According to the lever principle, it is designed and manufactured in the form of eccentric hook, which can easily and quickly load the main engine of penetrometer.

1.7 Blowing dust ball:

It is used for blowing the dust and sand particles that may exist in the measuring hole to prevent the detection error caused by this.

1.8 Grinding wheel:

It is used to grind the surface of concrete to make it smooth, so as to eliminate the error that may occur when measuring the depth of measuring hole.

2. Technical parameters

1. Penetration force: $1000 \pm 10\text{N}$
2. Working stroke: $20 \pm 0.10\text{mm}$
3. Digital measuring stick range: $20\text{mm} + 0.01\text{mm}$
4. Measuring nail length: 40.00mm
5. Nail diameter: $3.5 \pm 0.05\text{mm}$
6. Gauge groove 39.5mm

Detecting steps

1).Grinding and leveling the surface of masonry joints with grinding wheel.

2). Take out the measuring nail from the box and insert it into the hole of the measuring nail seat (9) of the penetration rod (2), with the tip of the measuring pin facing outward. Then use the tightening wrench to tighten the nut of the measuring nail seat (9) to fix the measuring pin.

3). Hold the subject (1) of the penetrometer with one hand, and insert the long groove surface of the force lever (12) into the force groove rod at the rear of the penetrometer with the other hand, so that the force transverse pin of the force lever (12) and the stressing groove (6) match each other. Then hold the end of the force lever (12) with one hand, and slowly force the two hands inward. When the trigger (7) jumps, it indicates that the pothook (8) of the penetrometer has been hung

(When the force is applied, the force can be applied in any direction around 360° to extend the service life) . Take down the force adding lever (12), and then the penetrometer can enter the detection below.

4).During the test, hold the penetrometer horizontally in one hand, and let the flat head of the penetration instrument force against the polished and flat surface of the joint. Hold the instrument handle (5) firmly to prevent recoiling, then pull the trigger (7), and the penetrometer releases energy freely.

5). Finally, measure the depth of the hole with the Penetration depth measuring stick, press [HOLD] key to HOLD the measurement value, and read the measurement depth value directly from the display screen. In this way, a complete test is completed. The concrete compressive strength can be known by consulting the concrete compressive strength conversion table.

Arrangement of measuring points

1).When testing the compressive strength of concrete, components or structures with an area of no more than 25m^2 should be taken as one component.

2).When sampling inspection by batch, concrete with similar age, same floor, same source, same type, same variety and same strength grade and no more than 250m^3 shall be taken as a batch.The number of spot inspection should not be less than 30% of the total components, and should not be less than 6 components. The infrastructure can be counted as one floor.

3).The tested concrete should be smooth, and should avoid the edge of doors and Windows and embedded parts..

4).The decorative layer, painting layer, pointing concrete, floating slurry and surface damage layer within the detection range should be eliminated clean, The concrete to be tested should be exposed and polished before testing..

5).Each component shall be tested at 16 points, and the measuring points shall be evenly distributed on the horizontal concrete joint of the component. The horizontal distance between adjacent measuring points shall not be less than 240mm.

Note:

It is forbidden to face yourself or others in the direction of penetration end under the condition of force adding, so as to prevent accidents.

In order to prevent damage to the measuring nail seat, the force adding ejection should be avoided before installing the penetration nail.